

650V N-Channel Super Junction power MOSFET

DESCRIPTION

SJ MOSFET is a advanced technology for high voltage power MOSFETs, designed according to the super junction principle by Xinyuan semiconductor. The offered devices provide all benefits of a fast switching and low on resistance, making it especially suitable for applications which require more efficient, more compact, LED Lighting, High Performance Adapter etc..

Features

- Extremely low losses due to very low $R_{dson} * Q_g$
- Superior Avalanche Rugged Technology
- Fast switching capability
- 100% Avalanche Tested
- Pb-free lead plating; ROHS compliant

APPLICATIONS

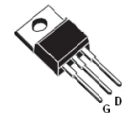
- Power factor correction (PFC)
- Switched mode power supplies(SMPS)
- Uninterruptible Power Supply (UPS)
- High Performance Adapter
- LED Lighting Power

V_{DS}	650	V
$R_{DS(ON)}$	290	m Ω
I_D	15	A

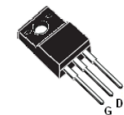
TO-252



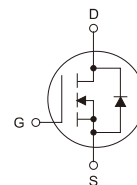
TO-220



TO-220F



TO-263-2L



ORDERING INFORMATION

Temperature Range	Package	Orderable Device	Package Qty.
-55°C ~ +125°C	TO-252	CWS65R290AD	75 PCS/Tube
	TO-220	CWS65R290ADR	2500 PCS/ R&T
	TO-220F	CWS65R290AC	50 PCS/Tube
	TO-263-2L	CWS65R290AF	50 PCS/Tube
			CWS65R290AX



ABSOLUTE MAXIMUM RATINGS

($T_j=25^{\circ}\text{C}$, unless otherwise noted)

Parameter	Symbol	Value	Unit
Drain-Source Voltage ($V_{GS}=0\text{V}$)	V_{DSS}	650	V
Gate-Source Voltage ($V_{DS}=0\text{V}$, static)	V_{GS}	± 30	V
Continuous Drain Current ($T_C=25^{\circ}\text{C}$)(Note 1)	$I_{D(DC)}$	15	A
Continuous Drain Current ($T_C=100^{\circ}\text{C}$) (Note 1)	$I_{D(DC)}$	10	A
Pulsed Drain Current (Note 2)	I_{DM}	45	A
MOSFET dv/dt ruggedness, $V_{DS}\leq 480\text{V}$	dv/dt	50	V/nS
Single Pulsed Avalanche Energy (Note 3)	E_{AS}	300	mJ
Avalanche Energy, Repetitive (Note 1)	E_{AR}	0.7	mJ
Avalanche Current, Repetitive (Note 1)	I_{AR}	7.5	A
Maximum Power Dissipation ($T_C=25^{\circ}\text{C}$)	P_D	151	W
Operating, Storage Temperature Range	T_J, T_{STG}	-55~150	$^{\circ}\text{C}$

THERMAL CHARACTERISTICS

Parameter	Symbol	Min.	Typ.	Max.	Units
Thermal Resistance, Junction-to-Case	R_{thJC}	-	-	0.85	$^{\circ}\text{C}/\text{W}$
Thermal Resistance, Junction-to-Ambient	R_{thJA}	-	-	62	$^{\circ}\text{C}/\text{W}$

ELECTRICAL CHARACTERISTICS

($T_j = 25^{\circ}\text{C}$, unless otherwise noted)

Parameter	Symbol	Test Conditions	Min.	TYP.	Max.	Unit
Drain-Source Breakdown Voltage	BV_{DSS}	$V_{GS}=0\text{V}, I_D=250\mu\text{A}$	650	-	-	V
Zero Gate Voltage Drain Current	I_{DSS}	$V_{DS}=650\text{V}, V_{GS}=0\text{V}$	-	-	1	μA
Gate-Source Leakage Current	I_{GSS}	$V_{GS}=\pm 30\text{V}, V_{DS}=0\text{V}$	-	-	± 100	nA
Gate Threshold Voltage	$V_{GS(th)}$	$V_{DS}=V_{GS}, I_D=250\mu\text{A}$	2.5	3.0	3.5	V
Drain-Source On-state Resistance	$R_{DS(on)}$	$V_{GS}=10\text{V}, I_D=7.5\text{A}$	-	0.25	0.29	Ω
Gate Resistance	R_g	F=1MHZ, open drain	-	10.3	-	Ω



Dynamic Characteristics

($T_j = 25^\circ\text{C}$, unless otherwise noted)

Parameter	Symbol	Test Conditions	Min.	Typ.	Max.	Units
Input capacitance	C_{iss}	$V_{DS}=100\text{V}, V_{GS}=0\text{V},$ $f=1\text{MHz}$	-	1036	-	pF
Output capacitance	C_{oss}		-	44.2	-	
Reverse transfer capacitance	C_{rss}		-	2.16	-	
Turn-on delay Time	$t_{d(on)}$	$V_{DD}=480\text{V}, I_D=11\text{A}$ $R_G=6.8\Omega, V_{GS}=10\text{V}$	-	26	-	ns
Rise time	t_r		-	34		
Turn-off delay time	$t_{d(off)}$		-	109		
Fall time	t_f		-	36		

Gate charge characteristics

($T_j = 25^\circ\text{C}$, unless otherwise noted)

Parameter	Symbol	Test Conditions	Min.	Typ.	Max.	Units
Gate to Source Charge	Q_{gs}	$V_{DD}=480\text{V}, I_D=11\text{A}$ $V_{GS}=0$ to 10V	-	5.0	-	nC
Gate to Drain Charge	Q_{gd}		-	8.4	-	
Gate Charge Total	Q_g		-	24	-	
Gate Plateau Voltage	$V_{plateau}$		-	4.4	-	V

Reverse diode characteristics

($T_j = 25^\circ\text{C}$, unless otherwise noted)

Parameter	Symbol	Test Conditions	Min.	Typ.	Max.	Units
Body Diode Forward Voltage	V_{SD}	$V_{GS}=0\text{V}, I_{SD}=11\text{A}$	-	0.9	-	V
Reverse Recovery Time	t_{rr}	$V_R=480\text{V}, I_F=11\text{A}$ $di_F/dt=100\text{A}/\mu\text{s}$	-	270	-	nS
Reverse Recovery Charge	Q_{rr}		-	4.1	-	μC
Peak Reverse Recovery Current	I_{rrm}		-	22.8	-	A

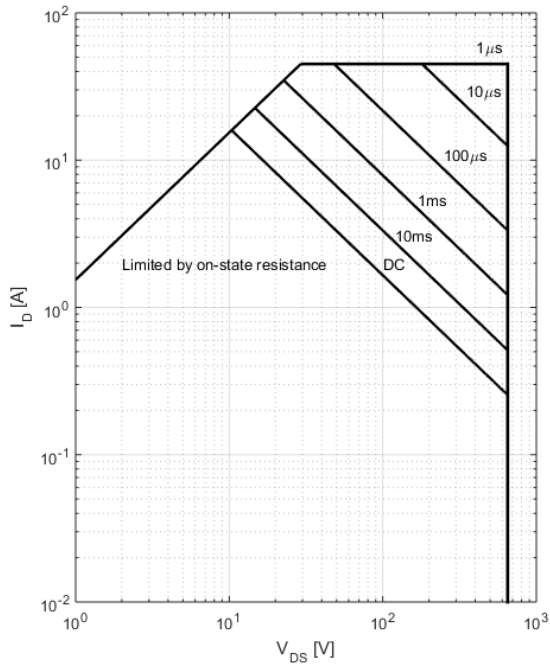
Notes:

- Limited by maximum junction temperature;
- Pulse width limited by maximum junction temperature;
- $I_{AS} = 7.5\text{ A}$, $V_{DD} = 50\text{ V}$, $R_G = 25\ \Omega$, Starting $T_j = 25^\circ\text{C}$.



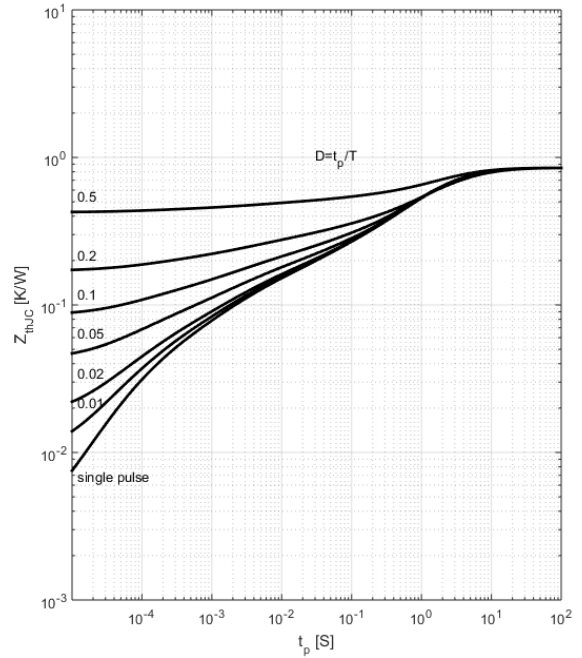
ELECTRICAL CHARACTERISTICS DIAGRAMS

Figure 1. Safe operating area



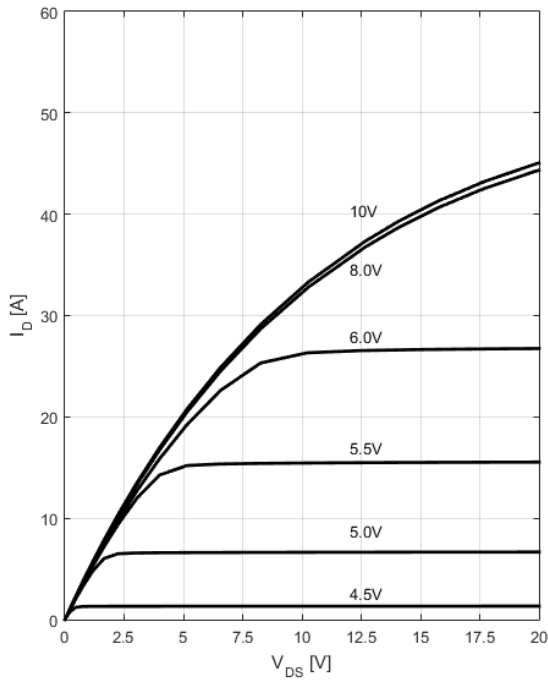
$I_D=f(V_{DS})$; $T_c=25\text{ }^\circ\text{C}$; parameter t_p

Figure 2. Transient thermal impedance



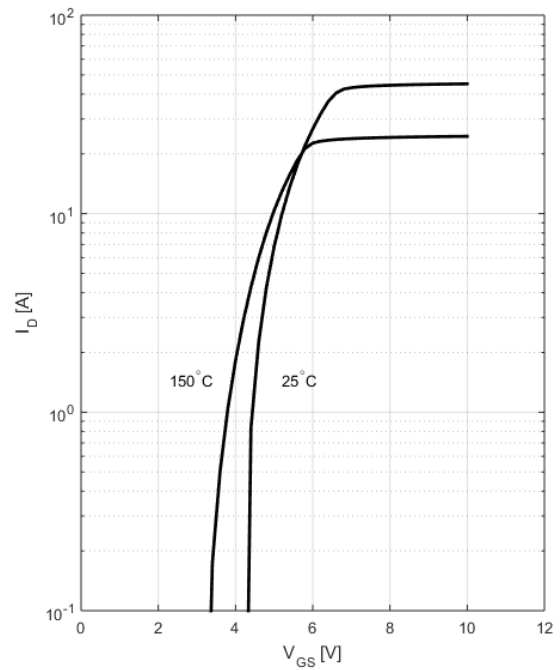
$Z_{(thJC)}=f(t_p)$; parameter: $D=t_p/T$

Figure3. Typ. output characteristics



$I_D=f(V_{DS})$; $T_j=25\text{ }^\circ\text{C}$; parameter: V_{GS}

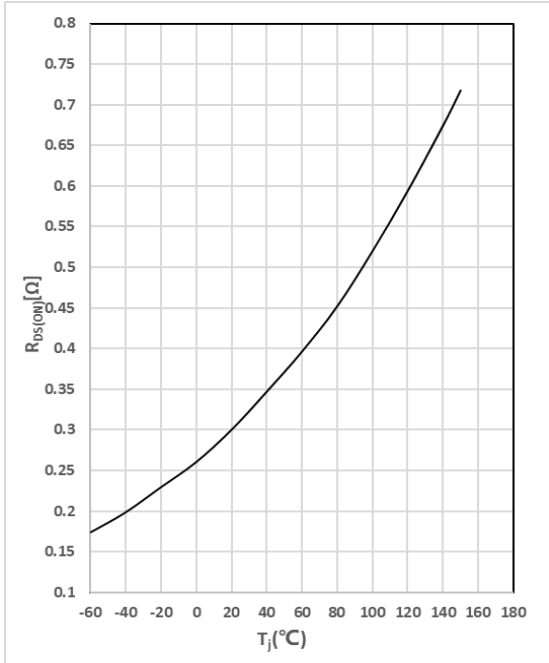
Figure 4. Typ. transfer characteristics



$I_D=f(V_{GS})$; $V_{DS}=20\text{V}$

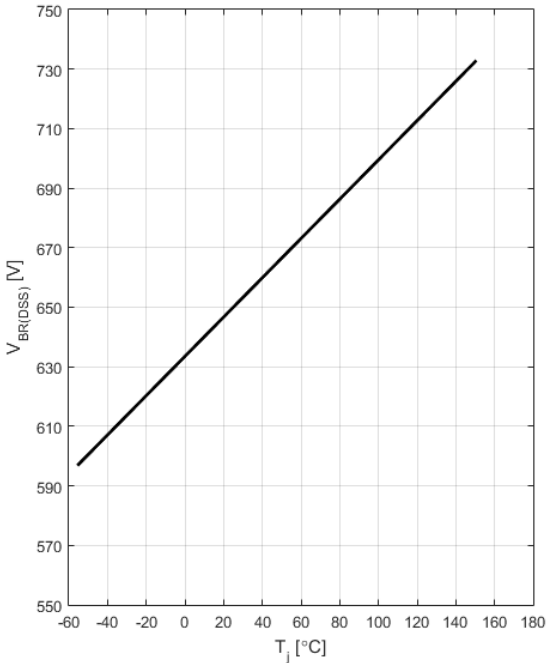


Figure 5. Drain-source on-state resistance



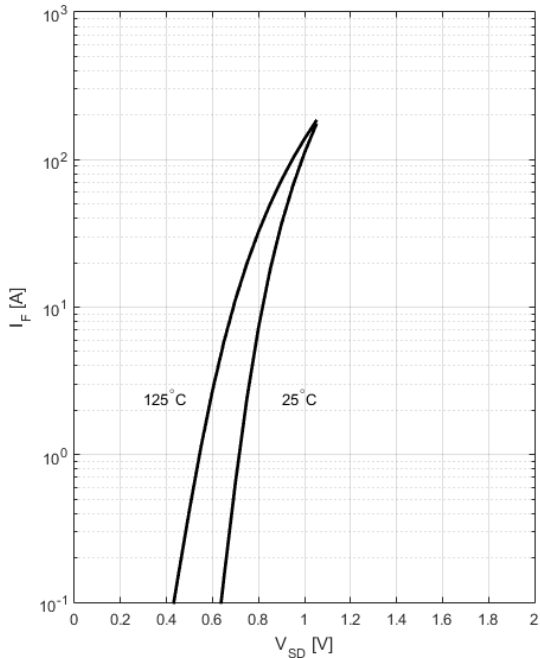
$R_{DS(ON)}=f(T_j); I_D=15A; V_{GS}=10V$

Figure6. Drain-source breakdown voltage



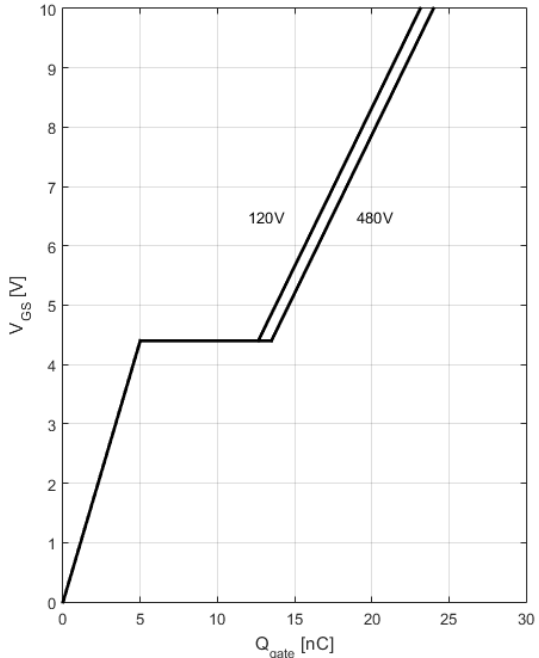
$V_{BR(DSS)}=f(T_j); I_D=10mA$

Figure7. Forward characteristics of reverse diode



$I_F=f(V_{SD}); \text{parameter: } T_j$

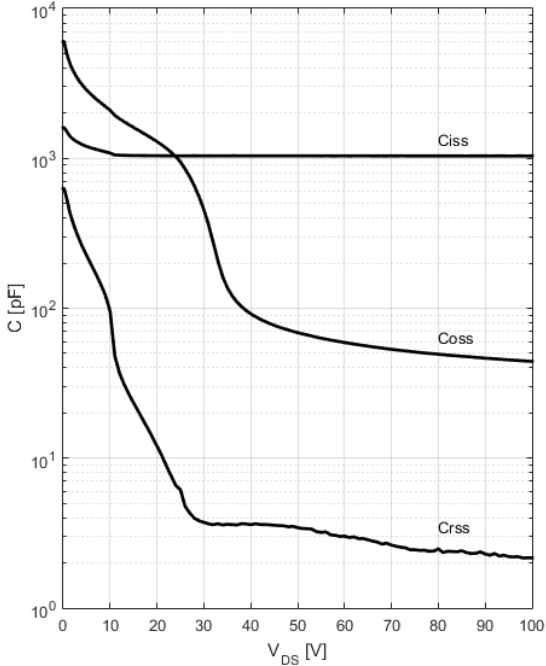
Figure 8. Typ. gate charge



$V_{GS}=f(Q_{gate}), I_D=15A \text{ pulsed}$

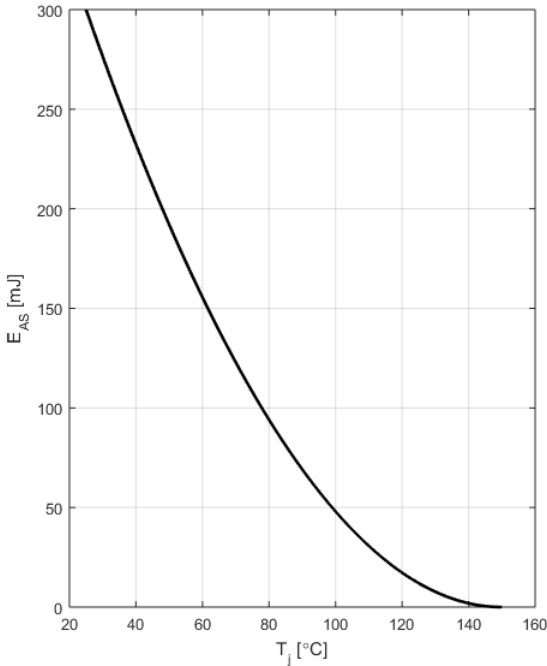


Figure 9: Typ. capacitances



$C=f(V_{DS}); V_{GS}=0; f=1MHz$

Figure 10: Avalanche energy

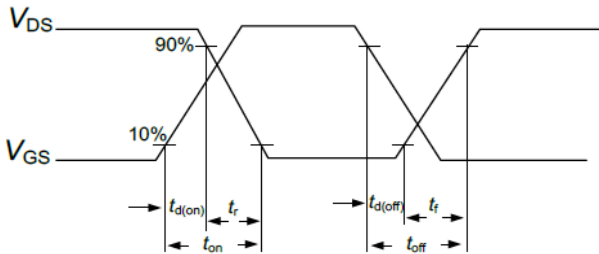
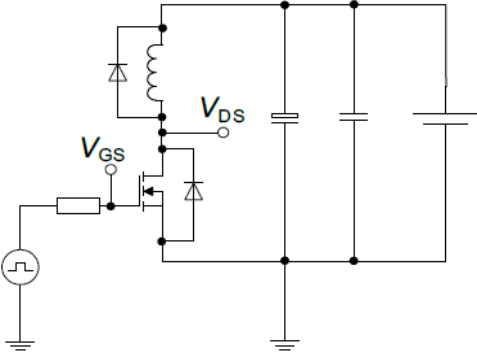


$E_{AS}=f(T_j); I_D=7.5A; V_{DD}=50V$

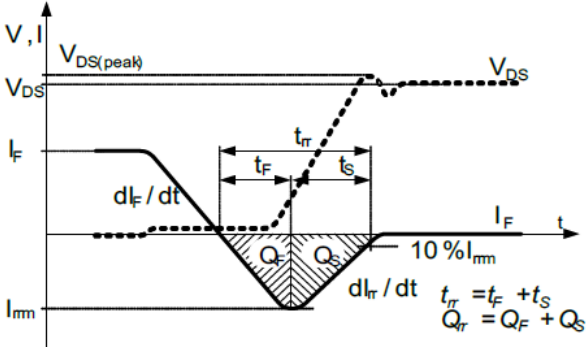
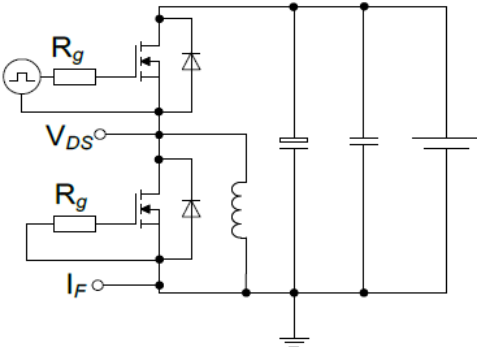


Test Circuits

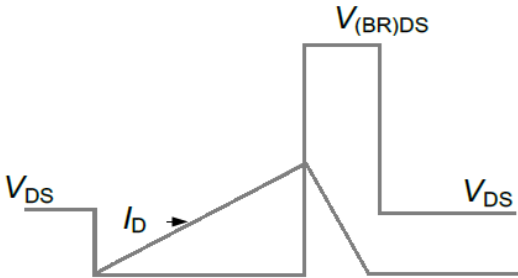
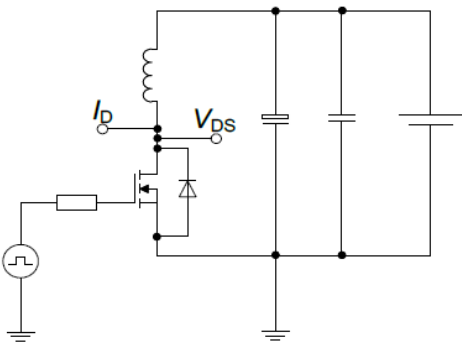
Switch time test circuit



Reverse diode characteristics test circuit and waveform

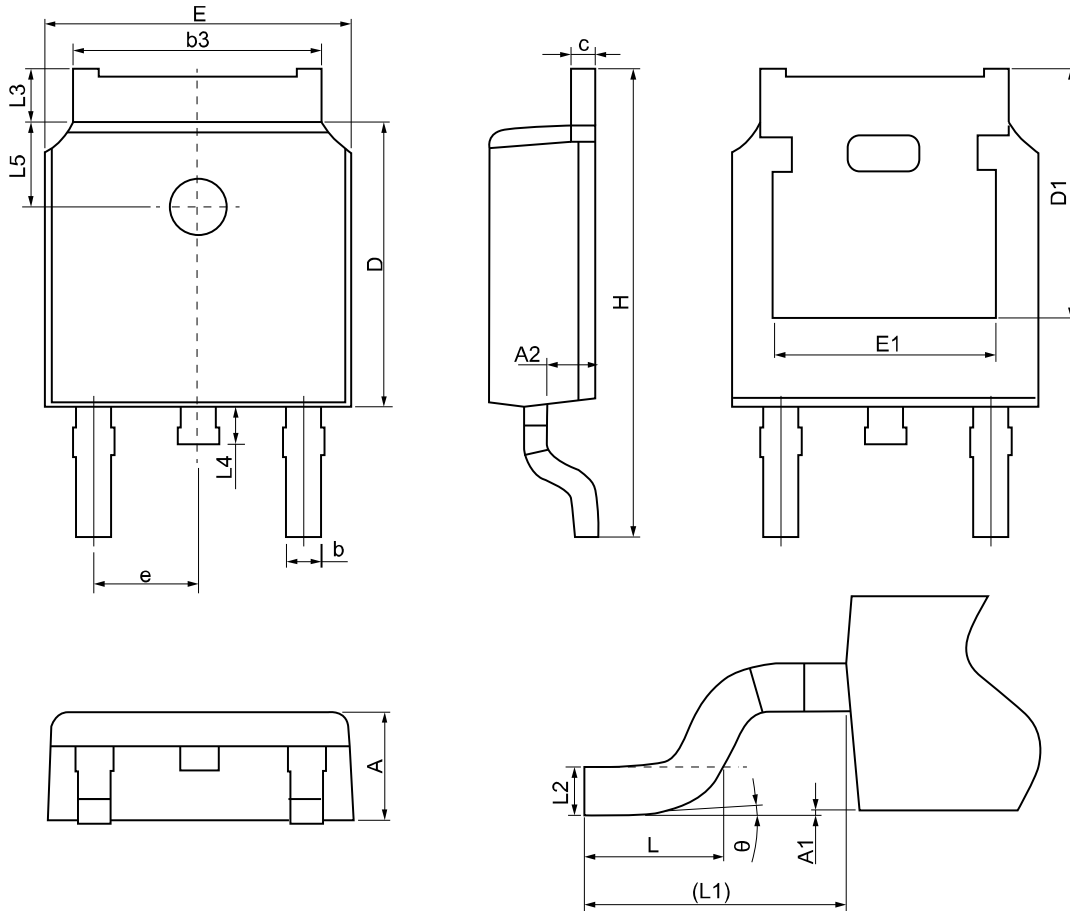


Unclaimed inductive switching test circuit & waveform



PHYSICAL DIMENSIONS

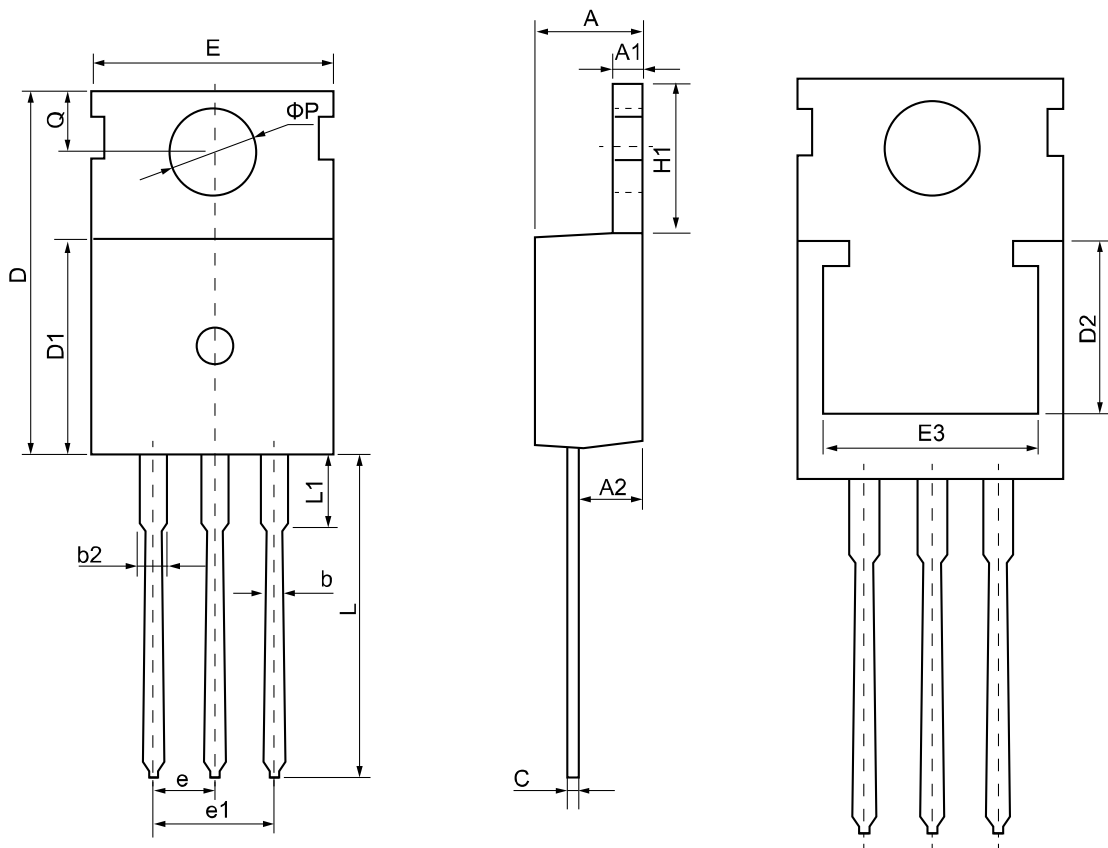
TO-252



Symbol	Dimension (mm)			Symbol	Dimension (mm)		
	Min	Nom	Max		Min	Nom	Max
A	2.20	2.30	2.40	e	2.286(BSC)		
A1	0.00	-	0.20	H	9.40	10.10	10.50
A2	0.97	1.07	1.17	L	1.38	1.50	1.75
b	0.68	0.78	0.90	L1	2.90(REF)		
b3	5.20	5.33	5.50	L2	0.51(BSC)		
c	0.43	0.53	0.63	L3	0.88	-	1.28
D	5.98	6.10	6.22	L4	0.50	-	1.00
D1	5.30(REF)			L5	1.65	1.80	1.95
E	6.40	6.60	6.80	θ	0°	-	8°
E1	4.63	-	-	-	-	-	-



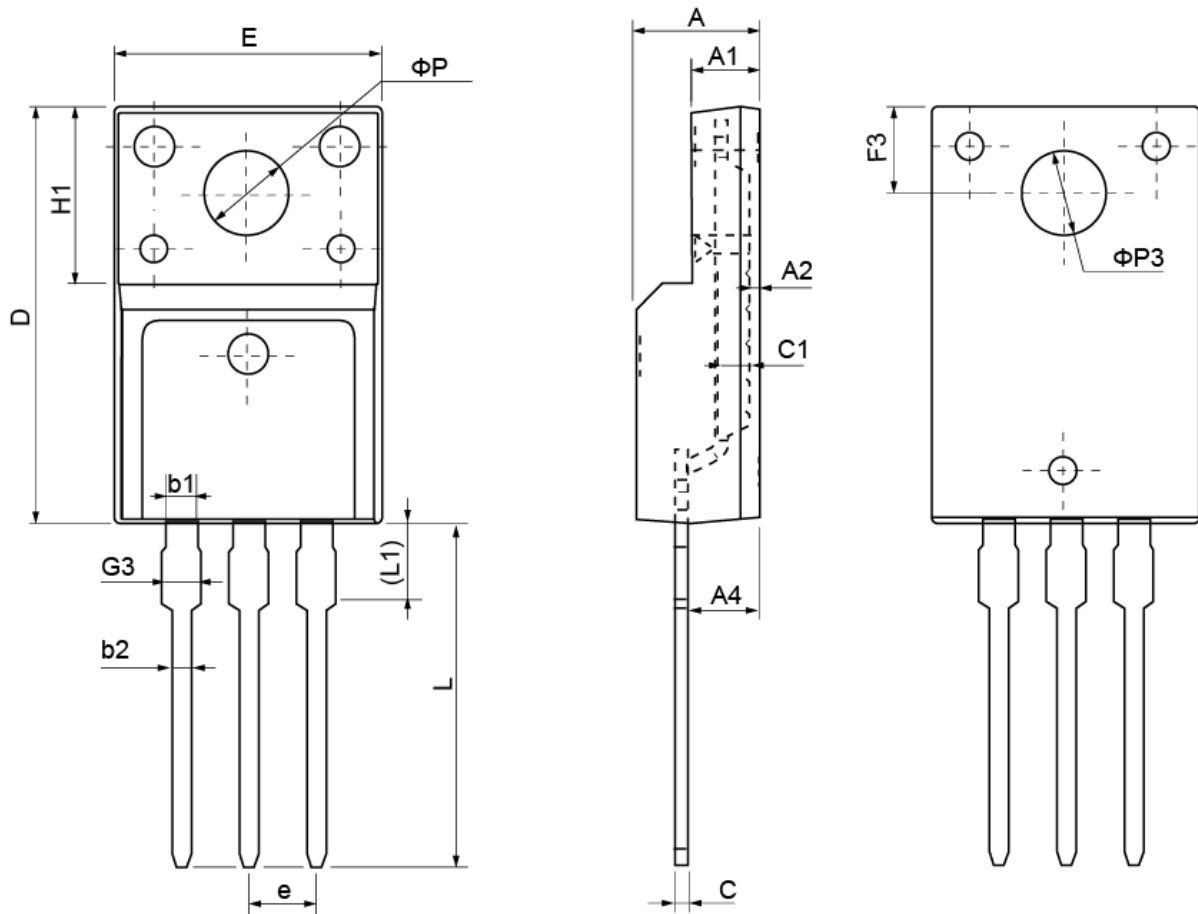
TO-220



Symbol	Dimension (mm)			Symbol	Dimension (mm)		
	Min	Nom	Max		Min	Nom	Max
A	4.37	4.57	4.77	E	9.80	10.00	10.20
A1	1.25	1.30	1.45	E3	7.00	-	-
A2	2.20	2.40	2.60	e	2.54(BSC)		
b	0.70	0.80	0.95	e1	5.08(BSC)		
b2	1.17	1.27	1.47	H1	6.30	6.50	6.80
c	0.40	0.50	0.65	L	12.75	13.50	13.80
D	15.30	15.60	15.90	L1	-	3.10	3.40
D1	8.90	9.10	9.30	ΦP	3.40	3.60	3.80
D2	5.50	-	-	Q	2.60	2.80	3.00



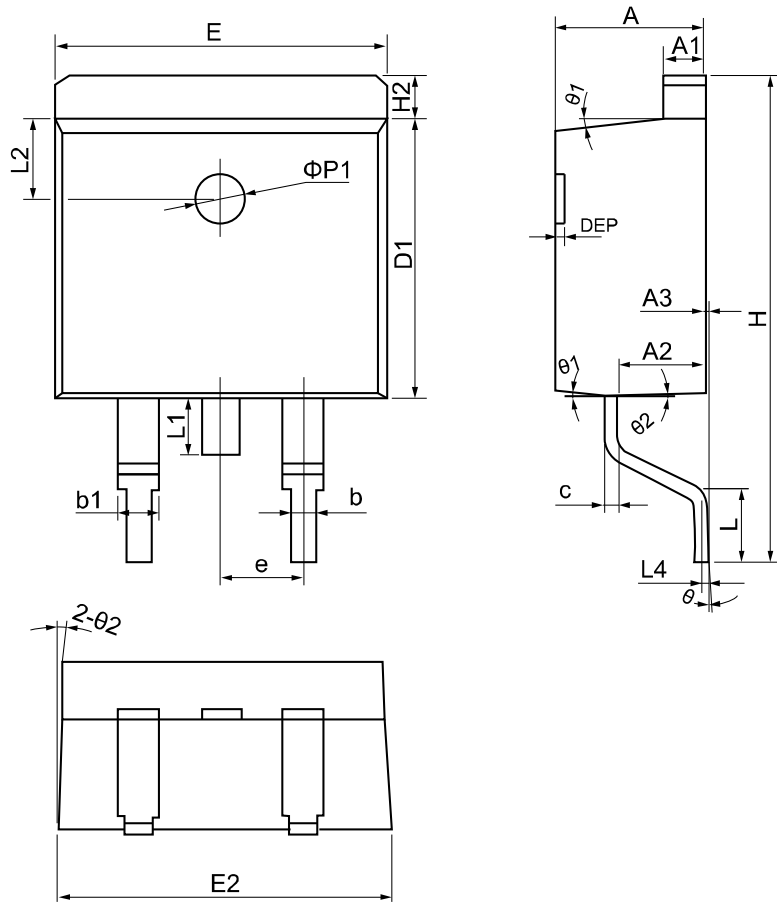
TO-220F



Symbol	Dimension (mm)			Symbol	Dimension (mm)		
	Min	Nom	Max		Min	Nom	Max
E	9.96	10.16	10.36	e	2.54(BSC)		
A	4.50	4.70	4.90	L	12.68	12.98	13.28
A1	2.34	2.54	2.74	L1	2.93	3.03	3.13
A2	0.30	0.45	0.60	ΦP	3.03	3.18	3.38
A4	2.56	2.76	2.96	$\Phi P3$	3.15	3.45	3.65
c	0.40	0.50	0.65	F3	3.15	3.30	3.45
c1	1.20	1.30	1.35	G3	1.25	1.35	1.55
D	15.57	15.87	16.17	b1	1.18	1.28	1.43
H1	6.70(REF)			b2	0.70	0.80	0.95



TO-263-2L



Symbol	Dimension (mm)			Symbol	Dimension (mm)		
	Min	Nom	Max		Min	Nom	Max
A	4.40	4.57	4.70	H	14.70	15.10	15.50
A1	1.22	1.27	1.32	H2	1.17	1.27	1.40
A2	2.59	2.69	2.79	L	2.00	2.30	2.60
A3	0.00	0.10	0.20	L1	1.45	1.55	1.70
b	0.77	0.813	0.90	L2	2.50(REF)		
b1	1.20	1.270	1.36	L4	0.25(BSC)		
c	0.34	0.381	0.47	θ	0°	5°	8°
D1	8.60	8.70	8.80	θ1	5°	7°	9°
E	10.00	10.16	10.26	θ2	1°	3°	5°
E2	10.00	10.10	10.20	ΦP1	1.40	1.50	1.60
e	2.54(BSC)			DEP	0.05	0.10	0.20

< Copyright >

All the Patent, Copyright and IP contained in this document belong to Xinyuan semiconductor, shall not be reproduced, copied, or used in other ways without permission.

