

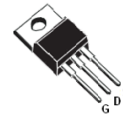
650V N-Channel Super Junction power MOSFET

DESCRIPTION

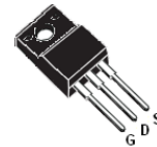
SJ MOSFET is an advanced technology for high voltage power MOSFETs, designed according to the super junction principle by Xinyuan semiconductor. The offered devices provide all benefits of a fast switching and low on resistance, making it especially suitable for applications which require more efficient, more compact, LED Lighting, High Performance Adapter etc..

V_{DS}	650	V
$R_{DS(ON)}$	190	m Ω
I_D	20	A

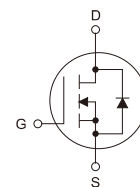
TO-220



TO-220F



TO-247



Features

- Extremely low losses due to very low $R_{dson} * Q_g$
- Superior Avalanche Rugged Technology
- Fast switching capability
- 100% Avalanche Tested
- Pb-free lead plating; ROHS compliant

APPLICATIONS

- Power factor correction (PFC)
- Switched mode power supplies(SMPS)
- Uninterruptible Power Supply (UPS)
- High Performance Adapter
- LED Lighting Power

ORDERING INFORMATION

Temperature Range	Package		Orderable Device	Package Qty.
-55°C ~ +125°C	TO-220	Pb-Free	CWS20N65AC	50 PCS/Tube
	TO-220F		CWS20N65AF	50 PCS/Tube
	TO-247		CWS20N65AZ	30 PCS/Tube



ABSOLUTE MAXIMUM RATINGS

($T_j=25^{\circ}\text{C}$, unless otherwise noted)

Parameter	Symbol	Value	Unit
Drain-Source Voltage ($V_{GS}=0\text{V}$)	V_{DSS}	650	V
Gate-Source Voltage ($V_{DS}=0\text{V}$, static)	V_{GS}	± 30	V
Continuous Drain Current ($T_C=25^{\circ}\text{C}$)(Note 1)	$I_{D(DC)}$	20	A
Continuous Drain Current ($T_C=100^{\circ}\text{C}$) (Note 1)	$I_{D(DC)}$	13	A
Pulsed Drain Current (Note 2)	I_{DM}	60	A
MOSFET dv/dt ruggedness, $V_{DS}\leq 480\text{V}$	dv/dt	50	V/nS
Single Pulsed Avalanche Energy (Note 3)	E_{AS}	500	mJ
Avalanche Energy, Repetitive (Note 1)	E_{AR}	1.3	mJ
Avalanche Current, Repetitive (Note 1)	I_{AR}	10	A
Maximum Power Dissipation ($T_C=25^{\circ}\text{C}$)	P_D	TO-220: 96 TO-220F: 33 TO-247: 130	W
Operating, Storage Temperature Range	T_J, T_{STG}	-55~150	$^{\circ}\text{C}$

THERMAL CHARACTERISTICS

Parameter	Symbol	Min.	Typ.	Max.	Units
Thermal Resistance, Junction-to-Case	R_{thJC}	-	-	TO-220: 1.3 TO-220F: 3.75 TO-247: 0.96	$^{\circ}\text{C}/\text{W}$
Thermal Resistance, Junction-to-Ambient	R_{thJA}	-	-	TO-220: 62 TO-220F: 80 TO-247: 57	$^{\circ}\text{C}/\text{W}$

ELECTRICAL CHARACTERISTICS

($T_j = 25^{\circ}\text{C}$, unless otherwise noted)

Parameter	Symbol	Test Conditions	Min.	TYP.	Max.	Unit
Drain-Source Breakdown Voltage	BV_{DSS}	$V_{GS}=0\text{V}, I_D=250\mu\text{A}$	650	-	-	V
Zero Gate Voltage Drain Current	I_{DSS}	$V_{DS}=650\text{V}, V_{GS}=0\text{V}$	-	-	1	μA
Gate-Source Leakage Current	I_{GSS}	$V_{GS}=\pm 30\text{V}, V_{DS}=0\text{V}$	-	-	± 100	nA
Gate Threshold Voltage	$V_{GS(th)}$	$V_{DS}=V_{GS}, I_D=250\mu\text{A}$	2.5	3.0	3.5	V
Drain-Source On-state Resistance	$R_{DS(on)}$	$V_{GS}=10\text{V}, I_D=10\text{A}$	-	0.17	0.19	Ω
Gate Resistance	R_g	F=1MHZ, open drain	-	5.3	-	Ω



Dynamic Characteristics

($T_j = 25^\circ\text{C}$, unless otherwise noted)

Parameter	Symbol	Test Conditions	Min.	Typ.	Max.	Units
Input capacitance	C_{iss}	$V_{DS}=100\text{V}, V_{GS}=0\text{V},$ $f=1\text{MHz}$	-	1580	-	pF
Output capacitance	C_{oss}		-	60.9	-	
Reverse transfer capacitance	C_{rss}		-	2.73	-	
Turn-on delay Time	$t_{d(on)}$	$V_{DD}=520\text{V}, I_D=20\text{A}$ $R_G=6.8\Omega, V_{GS}=10\text{V}$	-	40	-	ns
Rise time	t_r		-	173		
Turn-off delay time	$t_{d(off)}$		-	72		
Fall time	t_f		-	137		

Gate charge characteristics

($T_j = 25^\circ\text{C}$, unless otherwise noted)

Parameter	Symbol	Test Conditions	Min.	Typ.	Max.	Units
Gate to Source Charge	Q_{gs}	$V_{DD}=520\text{V}, I_D=20\text{A}$ $V_{GS}=0 \text{ to } 10\text{V}$	-	11	-	nC
Gate to Drain Charge	Q_{gd}		-	12	-	
Gate Charge Total	Q_g		-	37.1	-	
Gate Plateau Voltage	$V_{plateau}$		-	6.4	-	V

Reverse diode characteristics

($T_j = 25^\circ\text{C}$, unless otherwise noted)

Parameter	Symbol	Test Conditions	Min.	Typ.	Max.	Units
Body Diode Forward Voltage	V_{SD}	$V_{GS}=0\text{V}, I_{SD}=20\text{A}$	-	0.9	-	V
Reverse Recovery Time	t_{rr}	$V_R=520\text{V}, I_F=20\text{A}$ $di_F/dt=100\text{A}/\mu\text{s}$	-	350	-	nS
Reverse Recovery Charge	Q_{rr}		-	6.4	-	μC
Peak Reverse Recovery Current	I_{rrm}		-	29	-	A

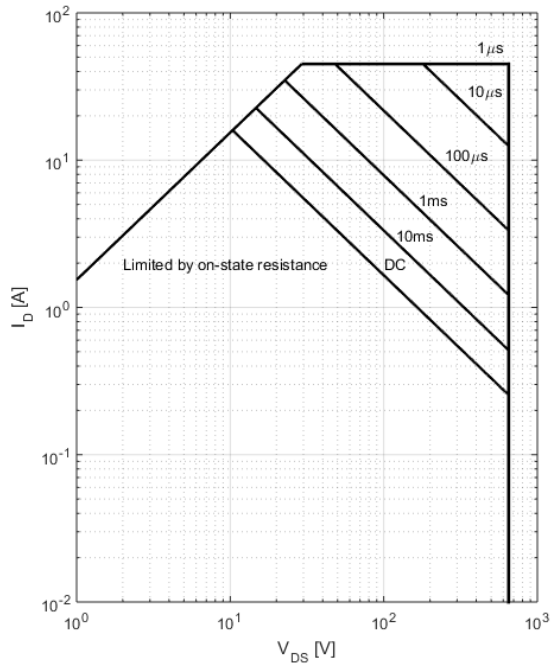
Notes:

- Limited by maximum junction temperature;
- Pulse width limited by maximum junction temperature;
- $I_{AS} = 10 \text{ A}$, $V_{DD} = 50 \text{ V}$, $R_G = 25 \Omega$, Starting $T_j = 25^\circ\text{C}$.



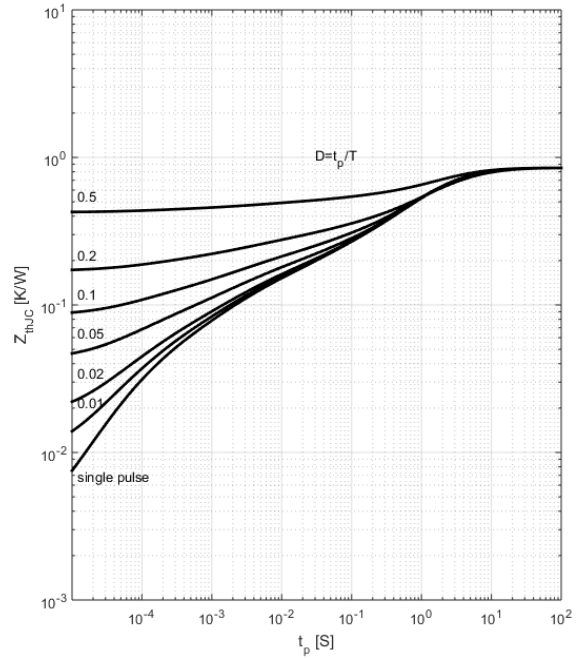
Electrical Characteristics Diagrams

Figure 1. Safe operating area



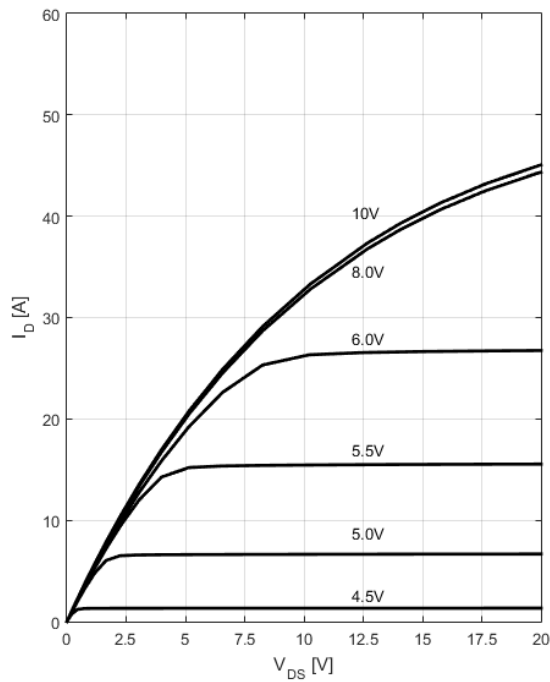
$I_D=f(V_{DS}); T_c=25\text{ }^\circ\text{C};$ parameter t_p

Figure 2. Transient thermal impedance



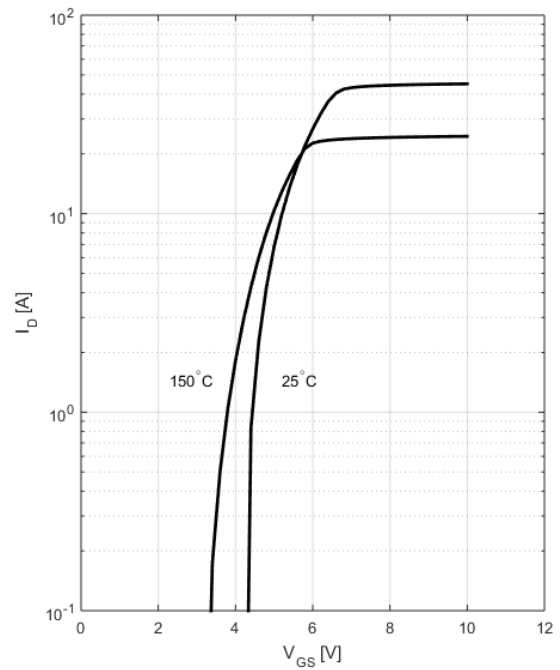
$Z_{(thJC)}=f(t_p);$ parameter: $D=t_p/T$

Figure3. Typ. output characteristics



$I_D=f(V_{DS}); T_j=25\text{ }^\circ\text{C};$ parameter: V_{GS}

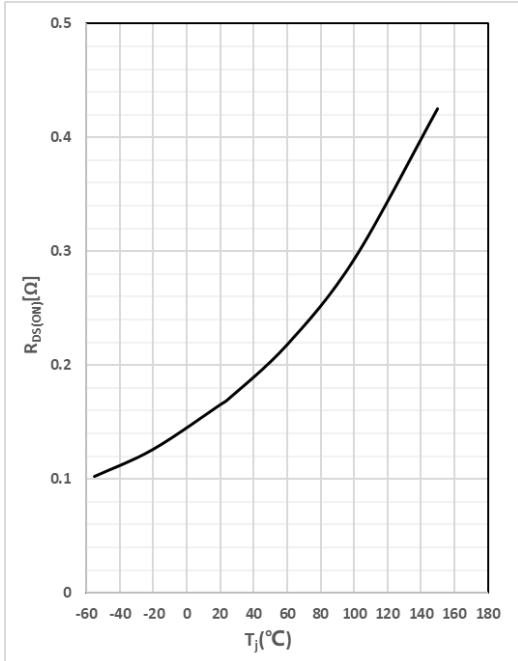
Figure 4. Typ. transfer characteristics



$I_D=f(V_{GS}); V_{DS}=20\text{V}$

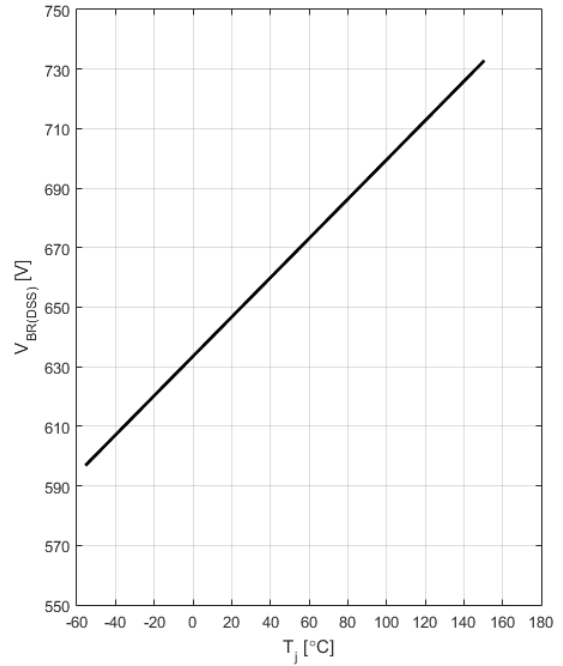


Figure 5. Drain-source on-state resistance



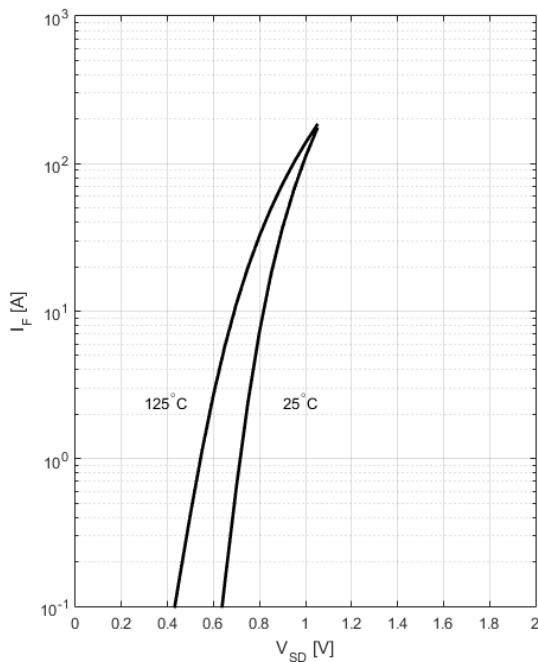
$R_{DS(ON)}=f(T_j); I_D=20A; V_{GS}=10V$

Figure6. Drain-source breakdown voltage



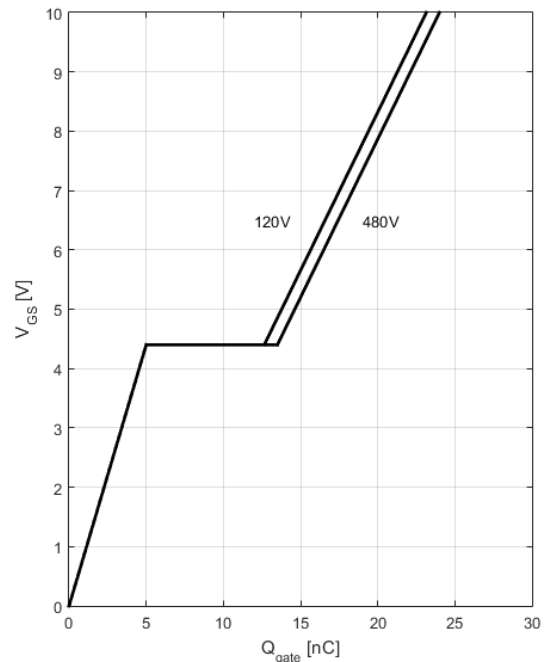
$V_{BR(DSS)}=f(T_j); I_D=10mA$

Figure7. Forward characteristics of reverse diode



$I_F=f(V_{SD}); \text{parameter: } T_j$

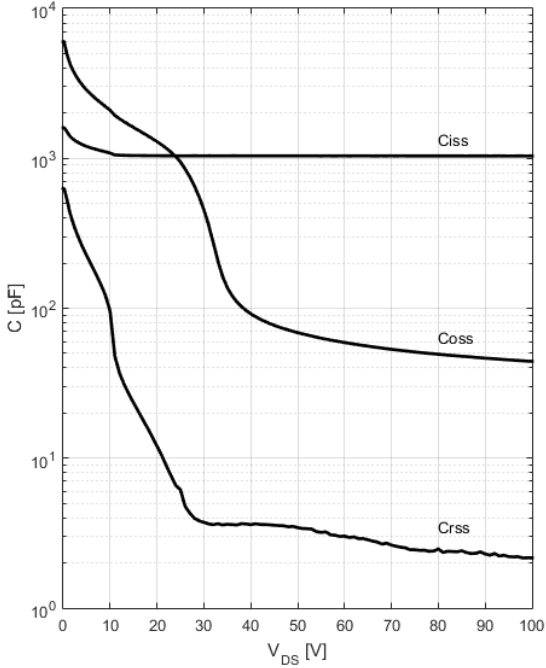
Figure 8. Typ. gate charge



$V_{GS}=f(Q_{gate}), I_D=20A \text{ pulsed}$

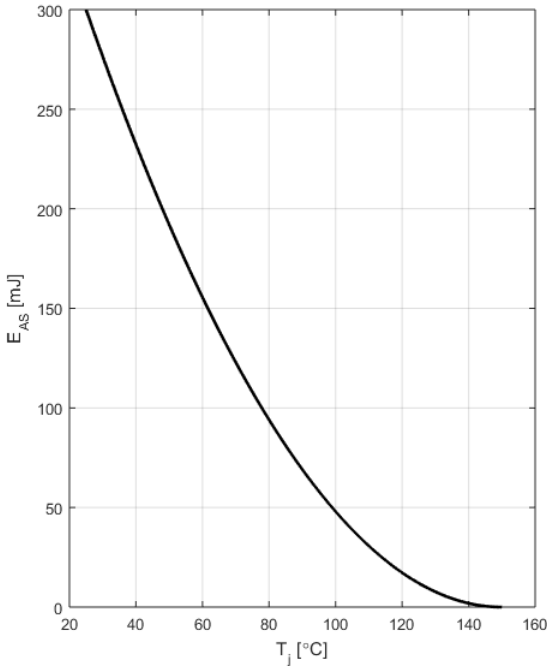


Figure 9: Typ. capacitances



$C=f(V_{DS}); V_{GS}=0; f=1\text{MHz}$

Figure 10: Avalanche energy

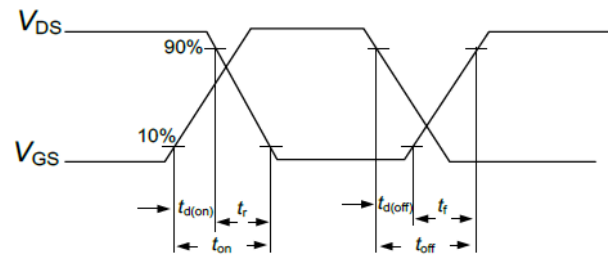
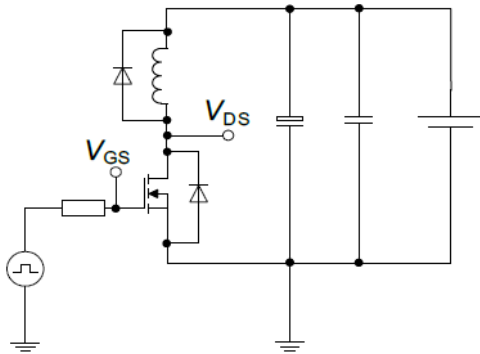


$E_{AS}=f(T_j); I_D=10\text{A}; V_{DD}=50\text{V}$

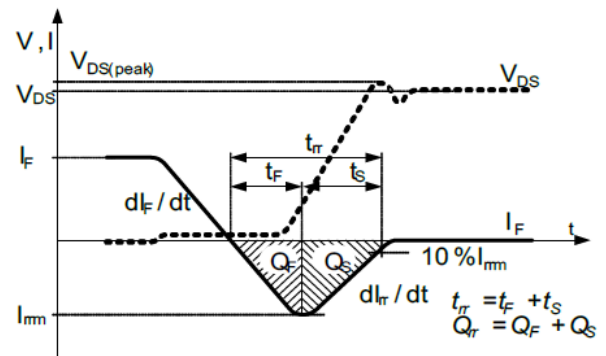
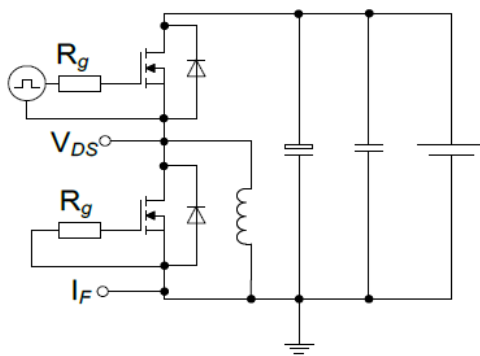


Test Circuits

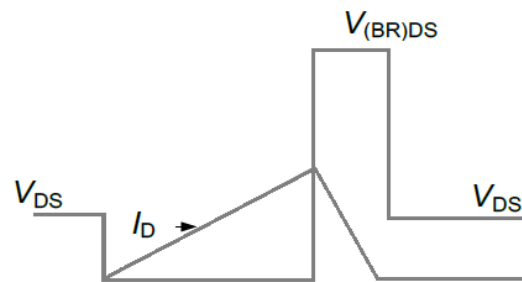
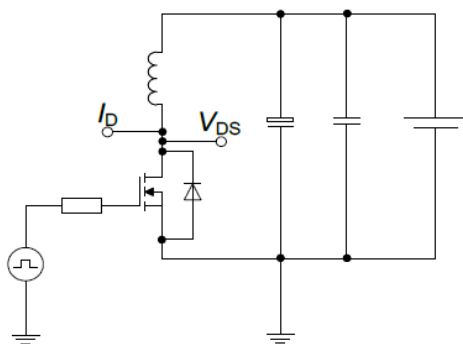
Switch time test circuit



Reverse diode characteristics test circuit and waveform

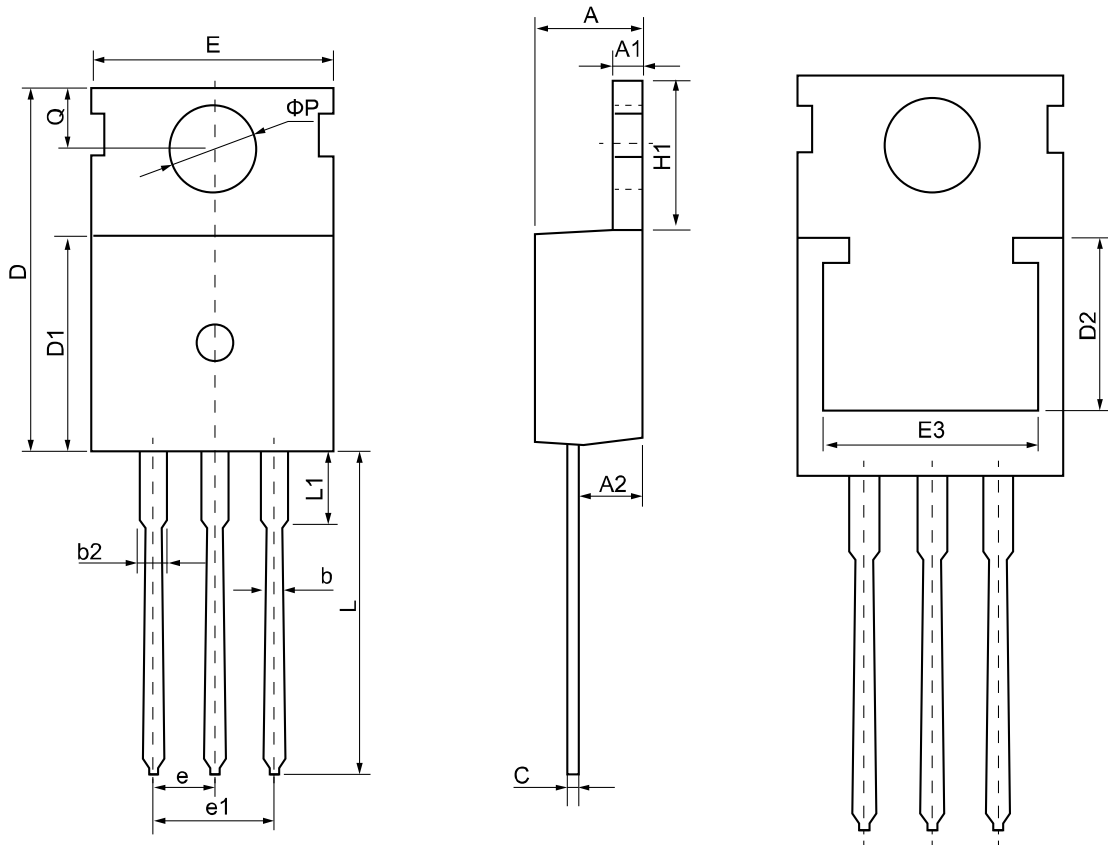


Unclamped inductive switching test circuit & waveform



PHYSICAL DIMENSIONS

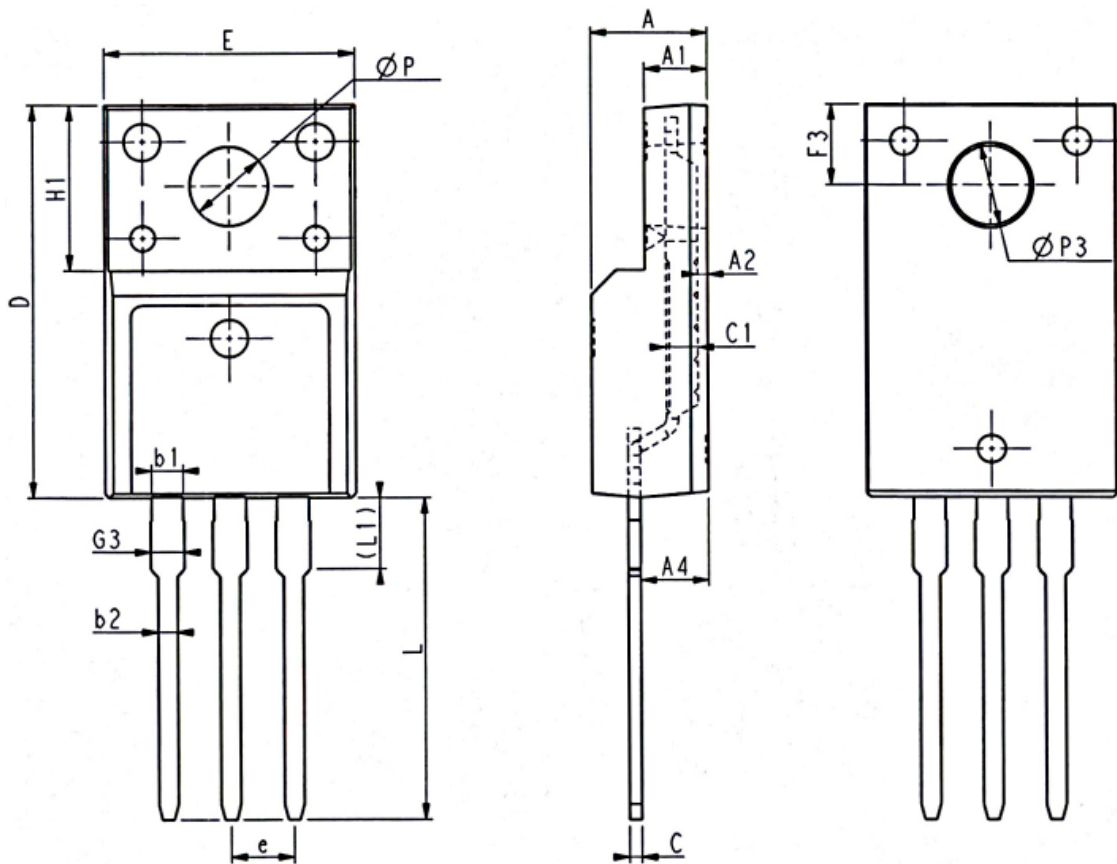
TO-220



Symbol	Dimension (mm)			Symbol	Dimension (mm)		
	Min	Nom	Max		Min	Nom	Max
A	4.37	4.57	4.77	E	9.80	10.00	10.20
A1	1.25	1.30	1.45	E3	7.00	-	-
A2	2.20	2.40	2.60	e	2.54(BSC)		
b	0.70	0.80	0.95	e1	5.08(BSC)		
b2	1.17	1.27	1.47	H1	6.30	6.50	6.80
c	0.40	0.50	0.65	L	12.75	13.50	13.80
D	15.30	15.60	15.90	L1	-	3.10	3.40
D1	8.90	9.10	9.30	ΦP	3.40	3.60	3.80
D2	5.50	-	-	Q	2.60	2.80	3.00



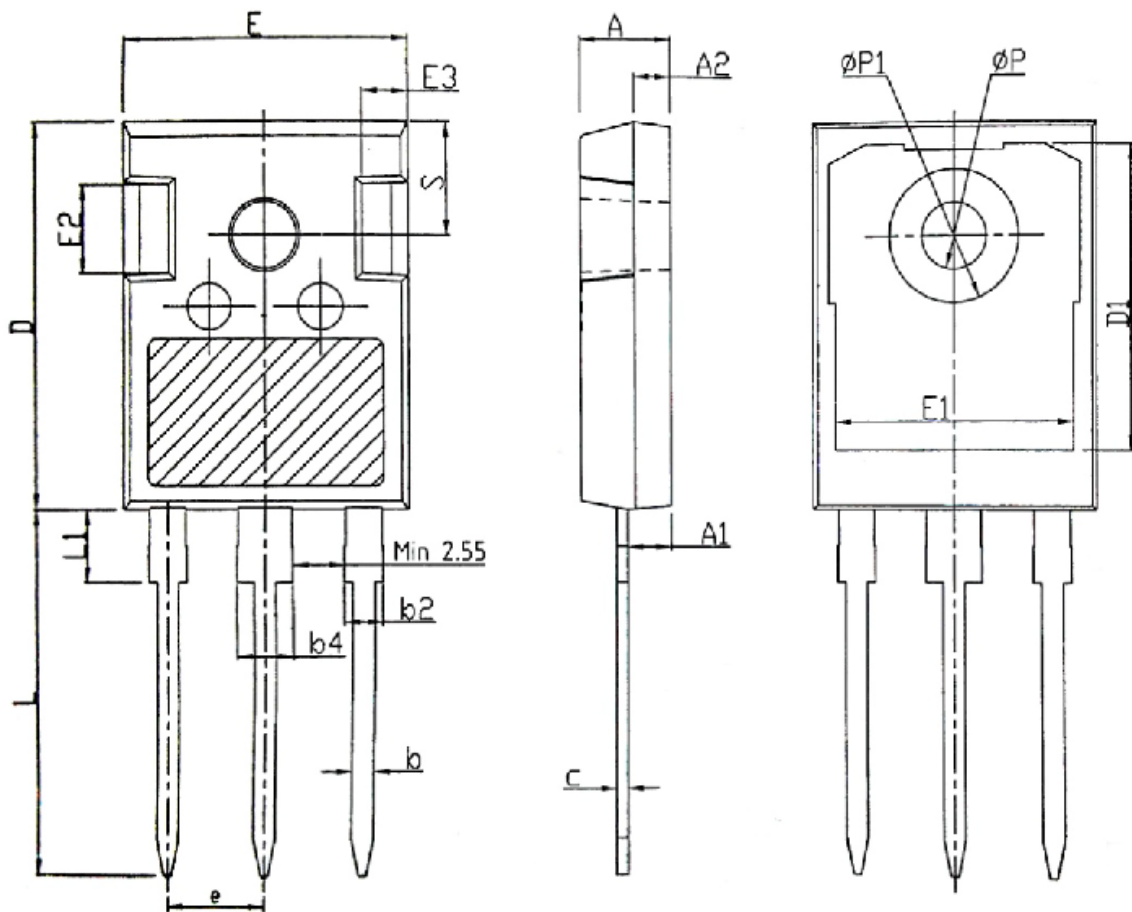
TO-220F



Symbol	Dimension (mm)			Symbol	Dimension (mm)		
	Min	Nom	Max		Min	Nom	Max
E	9.96	10.16	10.36	e	2.54(BSC)		
A	4.50	4.70	4.90	L	12.68	12.98	13.28
A1	2.34	2.54	2.74	L1	2.93	3.03	3.13
A2	0.30	0.45	0.60	ΦP	3.03	3.18	3.38
A4	2.56	2.76	2.96	ΦP3	3.15	3.45	3.65
c	0.40	0.50	0.65	F3	3.15	3.30	3.45
c1	1.20	1.30	1.35	G3	1.25	1.35	1.55
D	15.57	15.87	16.17	b1	1.18	1.28	1.43
H1	6.70(REF)			b2	0.70	0.80	0.95



TO-247



Symbol	Dimension (mm)			Symbol	Dimension (mm)		
	Min	Nom	Max		Min	Nom	Max
A	4.80	5.00	5.20	E1	13.00	13.30	13.60
A1	2.21	2.41	2.59	E2	4.80	5.00	5.20
A2	1.85	2.00	2.15	E3	2.30	2.50	2.70
b	1.11	1.21	1.36	e	5.44(BSC)		
b2	1.91	2.01	2.21	L	19.82	19.92	20.22
b4	2.91	3.01	3.21	L1	-	-	4.30
c	0.51	0.61	0.75	ϕP	3.40	3.60	3.80
D	20.80	21.00	21.30	$\phi P1$	-	-	7.30
D1	16.25	16.55	16.85	S	6.15(BSC)		
E	15.50	15.80	16.10	-	-	-	-

< Copyright >

All the Patent, Copyright and IP contained in this document belong to Xinyuan semiconductor, shall not be reproduced, copied, or used in other ways without permission.

